



NUMBER: 24-004-02

GROUP: Heating and A/C

DATE: March 18, 2002

This bulletin is supplied as technical information only and is not an authorization for repair. No part of this publication may be reproduced, stored in a retrieval system, or transmitted, in any form or by any means, electronic, mechanical, photocopying, or otherwise, without written permission of DaimlerChrysler Corporation.

SUBJECT:

Lack Of Air At Panel Vents

OVERVIEW:

This bulletin involves installing a new panel vent door assembly.

MODELS:

2002 (DR) Ram Truck

SYMPTOM/CONDITION:

Customers may indicate that there is a lack of air coming from the panel vents or that air is bleeding to the floor vents in the panel mode.

DIAGNOSIS:

Operate the heater A/C system in the panel mode at high blower speed. If the condition is present, perform the Repair Procedure.

PARTS REQUIRED:

Qty.	Part No.	Description
1	05086718AA	Panel Door

REPAIR PROCEDURE:

WARNING: ON VEHICLES EQUIPPED WITH AIRBAGS, DISABLE THE AIRBAG SYSTEM BEFORE ATTEMPTING ANY STEERING WHEEL, STEERING COLUMN, SEAT BELT TENSIONER, OR INSTRUMENT PANEL COMPONENT DIAGNOSIS OR SERVICE. DISCONNECT AND ISOLATE THE BATTERY NEGATIVE (GROUND) CABLE, THEN WAIT TWO MINUTES FOR THE AIRBAG SYSTEM CAPACITOR TO DISCHARGE BEFORE PERFORMING FURTHER DIAGNOSIS OR SERVICE. THIS IS THE ONLY SURE WAY TO DISABLE THE AIRBAG SYSTEM. FAILURE TO TAKE THE PROPER PRECAUTIONS COULD RESULT IN ACCIDENTAL AIRBAG DEPLOYMENT AND POSSIBLE PERSONAL INJURY.

NOTE: It is not necessary to completely remove the steering column. Lower the steering column from the instrument panel.

1. Disconnect and isolate the negative battery cable. Allow two minutes for the airbag system capacitor to discharge.

2. Using the procedures outlined 2002 Ram Truck Service Manual, publication number 81-370-02059 section 23, page 23-48, lower the steering column and remove the instrument panel to gain access to the heater A/C unit.
3. Locate the panel door actuator motor (Fig. 1) and remove the three attaching screws (Fig. 2). Move the actuator out of the way.

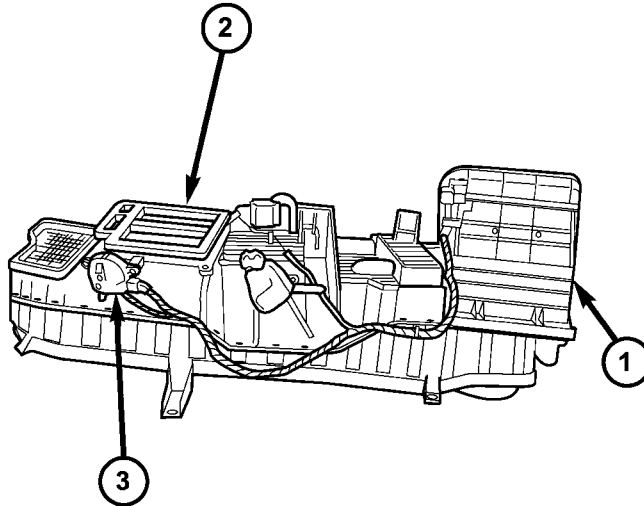

80ee1a20

Fig. 1 HEATER A/C UNIT

- 1 - Heater A/C Unit
 - 2 - Panel Door and Adaptor
 - 3 - Panel Door Actuator Motor
-

4. Remove and discard the panel door damper spring.
5. Remove the two adapter attaching screws (Fig. 2).

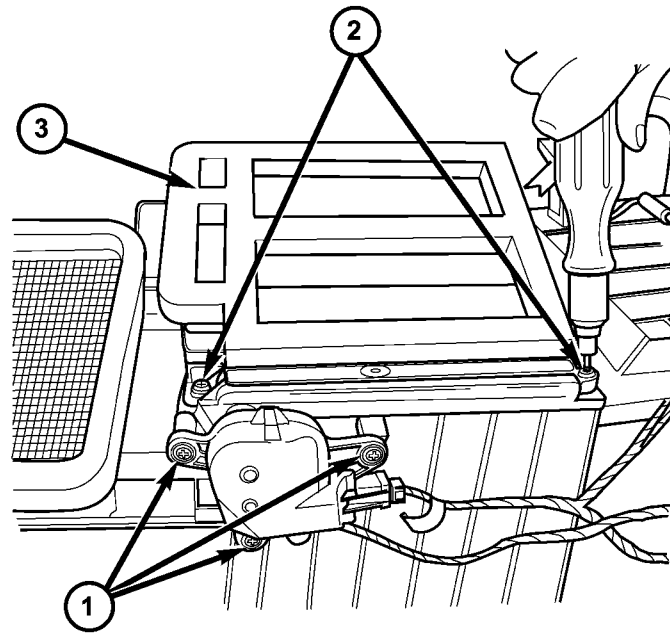

80ee1a34

Fig. 2 PANEL DOOR ADAPTER

- 1 - Panel Door Actuator
 - 2 - Adapter Screws
 - 3 - Adapter
-

6. Carefully remove the adapter from the housing by depressing the retainer tabs on the housing. These tabs are fragile and can break.
7. Remove the remainder of the panel door attaching screws. Remove and discard the panel door.
8. Position the new panel door, P/N 05086718AA on the housing. Install retaining screws removed earlier and the two new damper springs included with the door (Fig. 3).

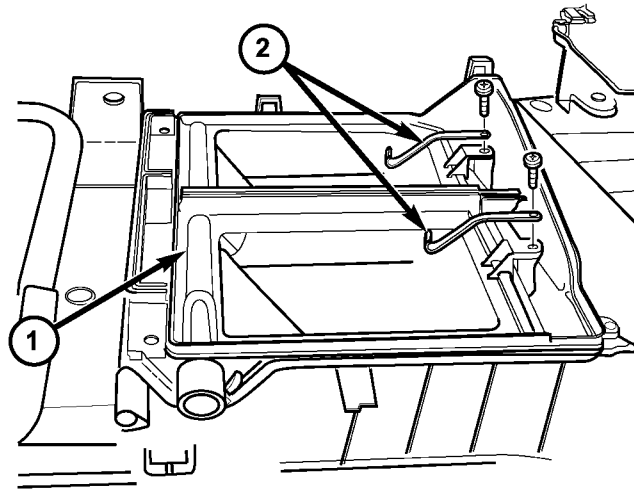

80ee1a3e

Fig. 3 PANEL DOOR

- 1 - Panel Door
- 2 - Damper Springs and Screws

9. Install the adapter and attaching screws.
10. Install the panel door actuator motor using care to route the wire harness so that it does not get trapped by the actuator.
11. Install the instrument panel and steering column.
12. Connect the battery cable.

POLICY:

Reimbursable within the provisions of the warranty.

TIME ALLOWANCE:

Labor Operation No:	Description	Amount
24-65-22-92	Install panel door	2.3 Hrs.

FAILURE CODE:

P8	New Part
----	----------