

## P0205-INJECTOR 5 CONTROL CIRCUIT

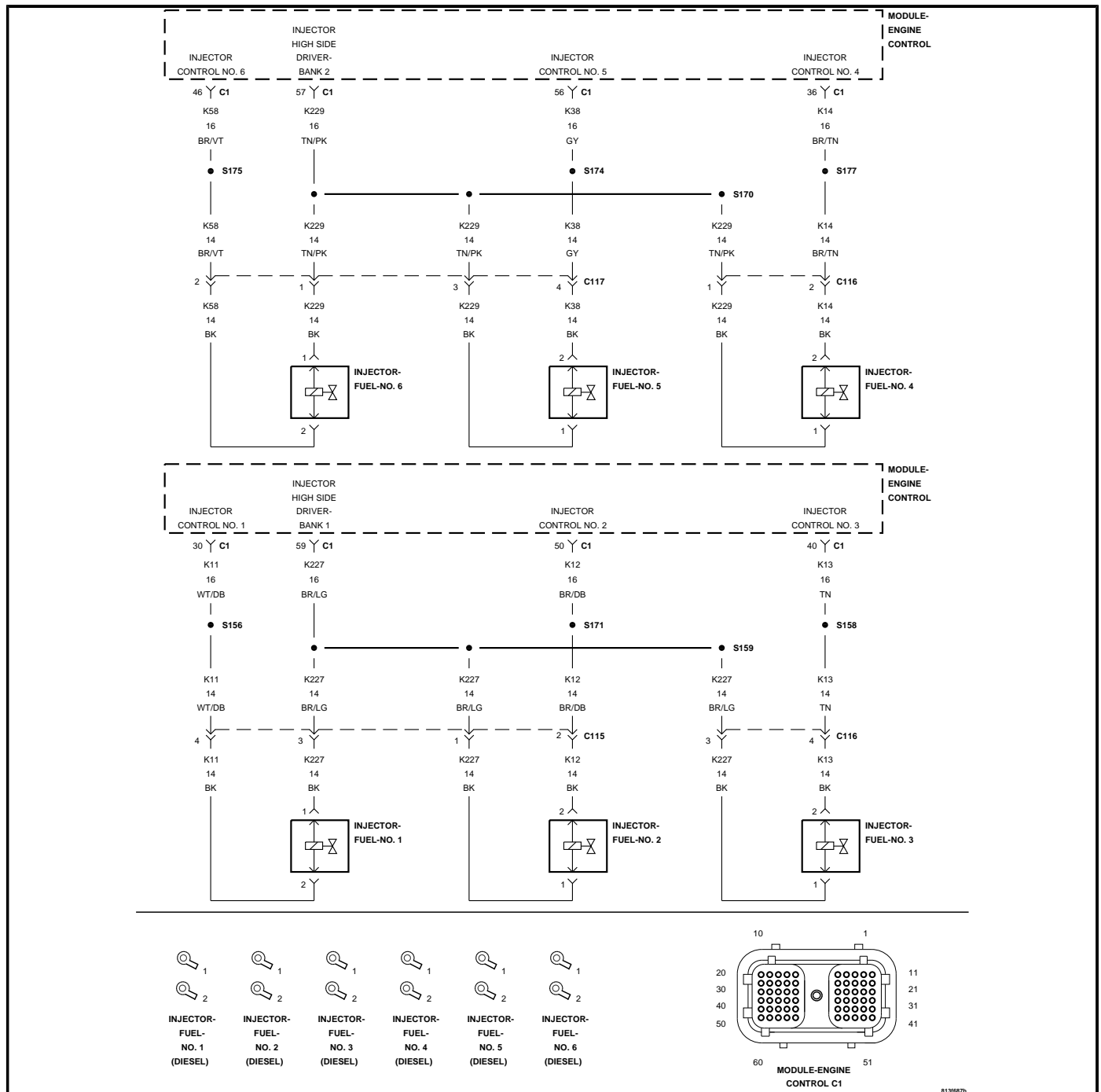

For a complete wiring diagram, refer to the Wiring Information.

- When Monitored:**

While the engine is running.

- **Set Condition:**

When the injector current falls below a calibrated threshold.

Possible Causes
PASS TROUGH CONNECTORS OPEN
INJECTOR HARNESS OPEN
HIGH SIDE DRIVER HARNESS OPEN
LOW SIDE DRIVER HARNESS OPEN
FUEL INJECTOR
ENGINE CONTROL MODULE (ECM)

**Always perform the Pre-Diagnostic Troubleshooting procedure before proceeding. (Refer to 28 - DTC-Based Diagnostics/MODULE, Engine Control (ECM) - Standard Procedure).**

### 1. OTHER DTCS

1. With the scan tool, read DTCs.

**Are all 6 of the injector DTCs (P0201 - P0206) present?**

**Yes** • Go To 2

**No** • Go To 3

### 2. PASS TROUGH CONNECTORS OPEN

1. Inspect wiring harness for signs of multiple open circuits between the ECM and the injector pass through connectors. Inspect the wiring harness between the pass through connectors to the injectors.

**Are there open circuits in the wiring harness?**

**Yes** • Repair or replace the open connectors or wiring.  
• Perform the POWERTRAIN VERIFICATION TEST (DIESEL). (Refer to 28 - DTC-Based Diagnostics/MODULE, Engine Control (ECM) - Standard Procedure).

**No** • Go To 3

### 3. FUEL INJECTOR

1. Turn the ignition off.
2. Disconnect the pigtail nuts from the suspect injector. Using an Ohmmeter, measure the resistance between the solenoid posts of the injector.

**NOTE:** Be sure to zero the Ohm meter prior to checking the injector circuit.

**Is the resistance less than 1.0 Ohm and greater than 0 Ohms?**

**Yes** • Go To 4

**No** • Replace the Fuel Injector.

- Perform the POWERTRAIN VERIFICATION TEST (DIESEL). (Refer to 28 - DTC-Based Diagnostics/MODULE, Engine Control (ECM) - Standard Procedure).

#### 4. INJECTOR HARNESS OPEN

1. Connect the pigtail nuts for the suspect injector.
2. Disconnect the injector harness connector for the suspect injector.
3. Measure the resistance of the injector harness circuit between the high side driver circuit and the low side driver circuit for the suspect injector at the injector harness connector.

**NOTE:** Be sure to zero the Ohm meter prior to checking the injector circuit.

**Is the resistance less than 1.0 Ohm and greater than 0 Ohms?**

- Yes**
- Go To 5
- No**
- Replace or repair the injector harness.
  - Perform the POWERTRAIN VERIFICATION TEST (DIESEL). (Refer to 28 - DTC-Based Diagnostics/MODULE, Engine Control (ECM) - Standard Procedure).

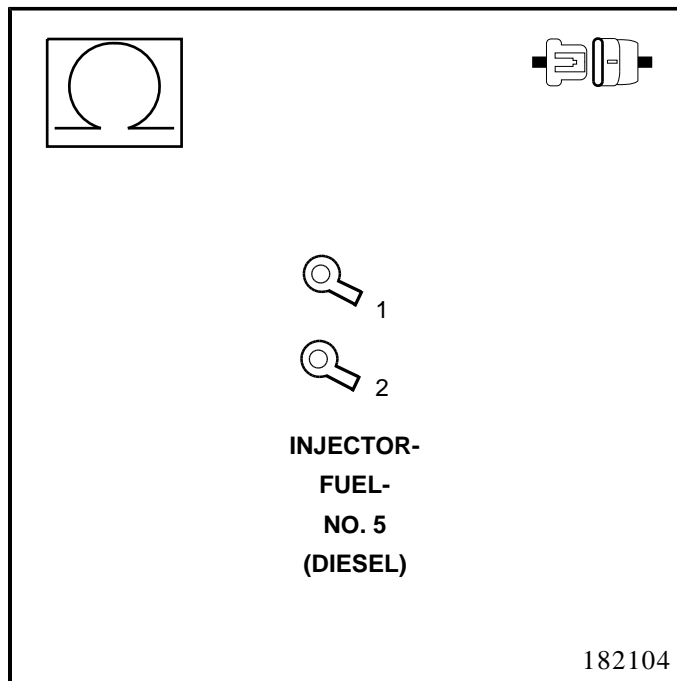

#### 5. HIGH SIDE DRIVER HARNESS OPEN

1. Disconnect the ECM harness connectors.
2. Disconnect the Injector harness connector.
3. Check connectors - Clean/repair as necessary.
4. Measure the resistance of the Bank 2 high side driver circuit between the ECM connector and the injector harness connector.

**Is the resistance less than 10.0 Ohms?**

- Yes**
- Go To 6
- No**
- Replace or repair the open engine harness.
  - Perform the POWERTRAIN VERIFICATION TEST (DIESEL). (Refer to 28 - DTC-Based Diagnostics/MODULE, Engine Control (ECM) - Standard Procedure).

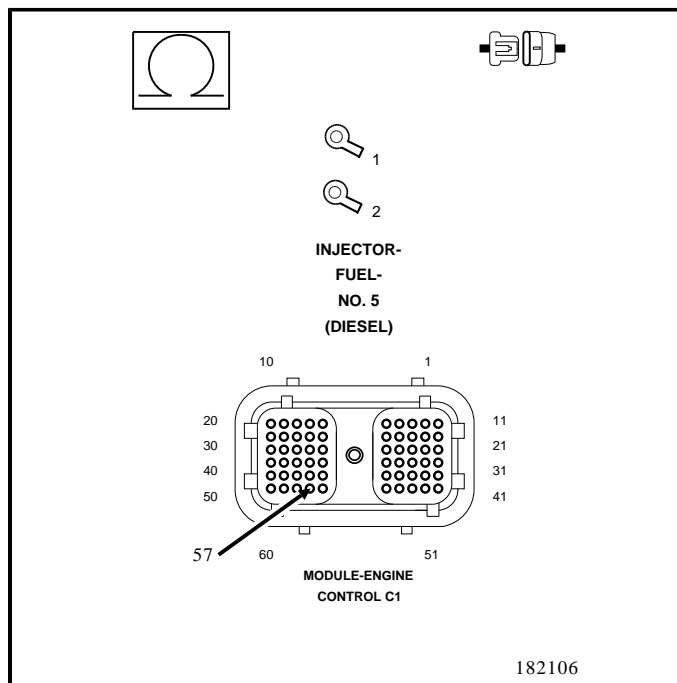

## 6. LOW SIDE DRIVER HARNESS OPEN

1. Measure the resistance of the Bank 2 low side driver circuit between the ECM connector and the injector harness connector.

### Is the resistance less than 10.0 Ohms?

- Yes**
- Replace and program the Engine Control Module (ECM) in accordance with the service information.
  - Perform the POWERTRAIN VERIFICATION TEST (DIESEL). (Refer to 28 - DTC-Based Diagnostics/MODULE, Engine Control (ECM) - Standard Procedure).
- No**
- Replace or repair the open engine harness.
  - Perform the POWERTRAIN VERIFICATION TEST (DIESEL). (Refer to 28 - DTC-Based Diagnostics/MODULE, Engine Control (ECM) - Standard Procedure).

