

1998-2002 Dodge 4th Gear Hunt Fix

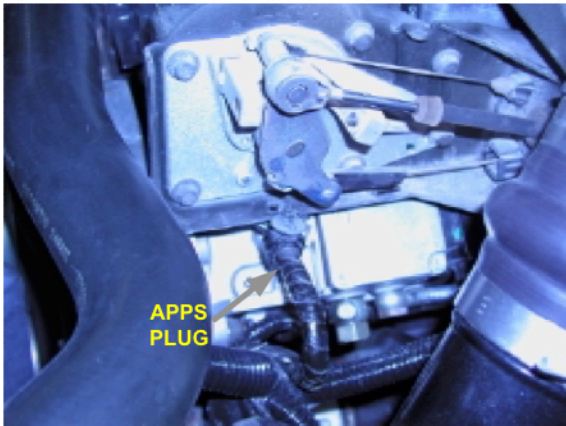
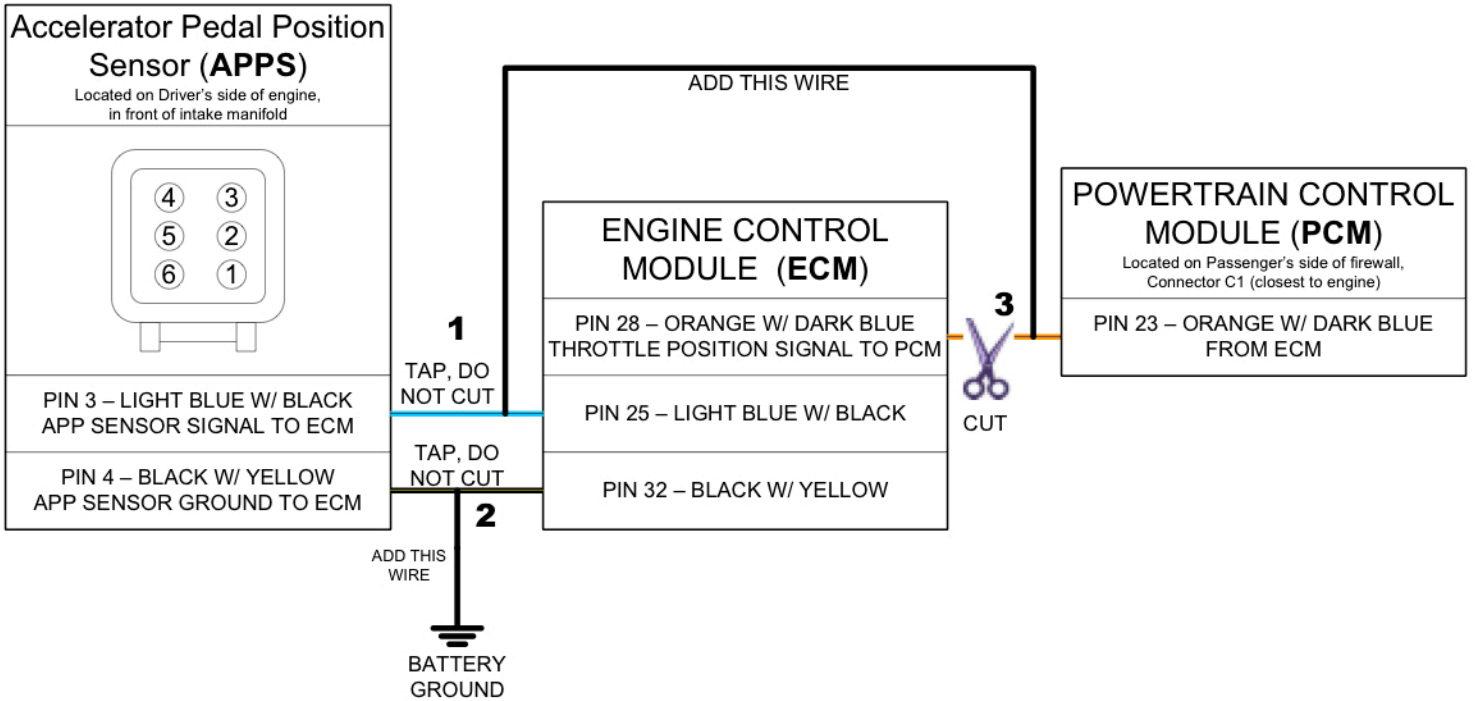

Figure 1: APPS

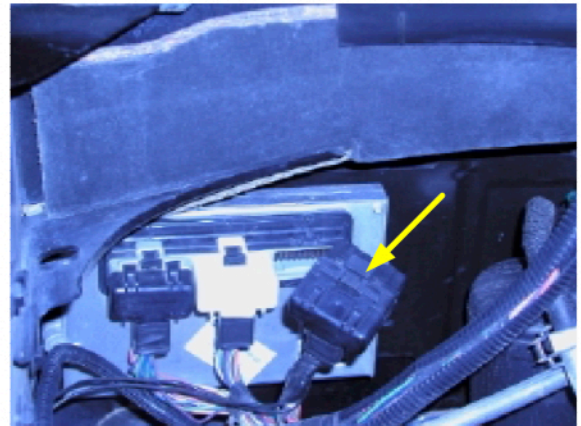

Figure 2: PCM Plug

PROCEDURE

Begin by disconnecting the negative terminals on both batteries.

- 1) Locate the **Light Blue wire with Black tracer** that runs to Pin 3 of the APPS plug (Driver's side of engine, in front of intake manifold, *under black plastic cover*). See figure 1 above. Tap (do not cut) this wire with a length of wire that will reach the PCM on the passenger's side firewall. We recommend that you run the wire along the driver's side of the engine to the firewall and across the firewall to the 3 PCM connectors. Secure this wire to the other wire looms that run along this path. Protect the connection from the elements.
- 2) Locate the **Black wire with Yellow tracer** that runs to Pin 4 of the APPS. Tap (do not cut) this wire with a length of wire that will reach the negative battery terminal and connect it to the that terminal. Secure this wire to other wires that run along this path.
- 3) Locate the **Orange wire with Dark Blue tracer** that runs into the PCM connector (shown in figure 2) which is closest to the engine (Pin 23). Cut this wire and attach the wire to the end of the of the orange wire with dark blue tracer that runs to the PCM. Leave the end of the orange wire with dark blue tracer that runs into the wire loom disconnected. See the above wiring diagram before performing this step. Protect the connection from the elements.

Reconnect both batteries.

- 4) Finally, recalibrate the APPS by turning the ignition to the ON or RUN position without starting the engine and slowly press the throttle pedal to the floor, then slowly release the pedal.