

TEST NS-15A CHECKING THE FUEL SHUTDOWN RELAY AND SOLENOID (DIESEL)

Perform TEST NS-SEL Before Proceeding

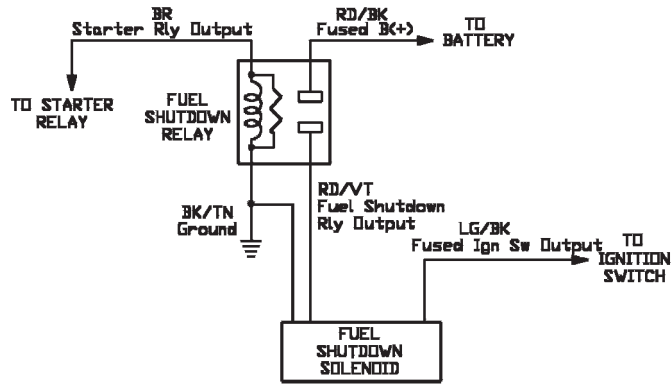

2310606

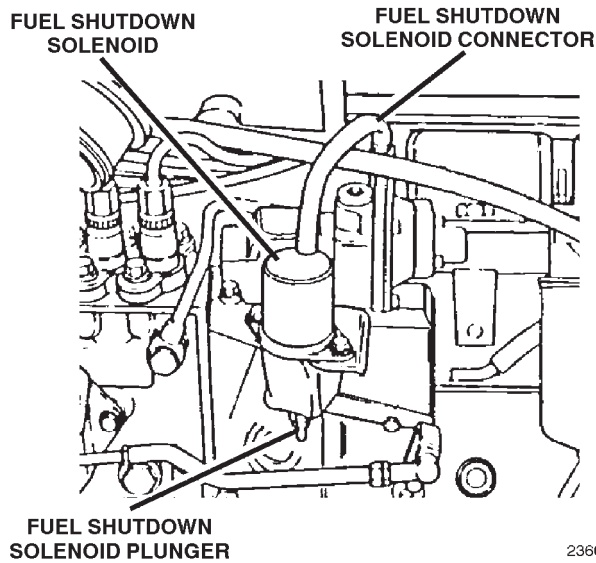
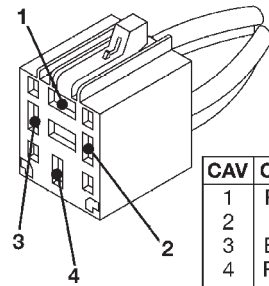

FIG. 1

2360502



FUEL SHUTDOWN RELAY CONNECTOR

CAV	COLOR	FUNCTION
1	RD/VT	Fuel Shutdown Relay Output
2	BR	Starter Relay Output
3	BK/TN	Ground
4	RD/BK	Fused B(+)

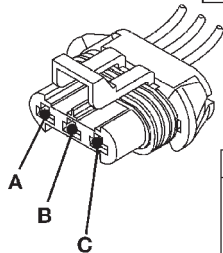

FUEL SHUTDOWN SOLENOID CONNECTOR

CAV	COLOR	FUNCTION
A	LG/BK	Fused Ignition Switch Output
B	RD/VT	Fuel Shutdown Relay Output
C	BK/TN	Ground

FIG. 2

80aa4be8

TEST NS-15A CHECKING THE FUEL SHUTDOWN RELAY AND SOLENOID (DIESEL)

Perform TEST NS-SEL Before Proceeding

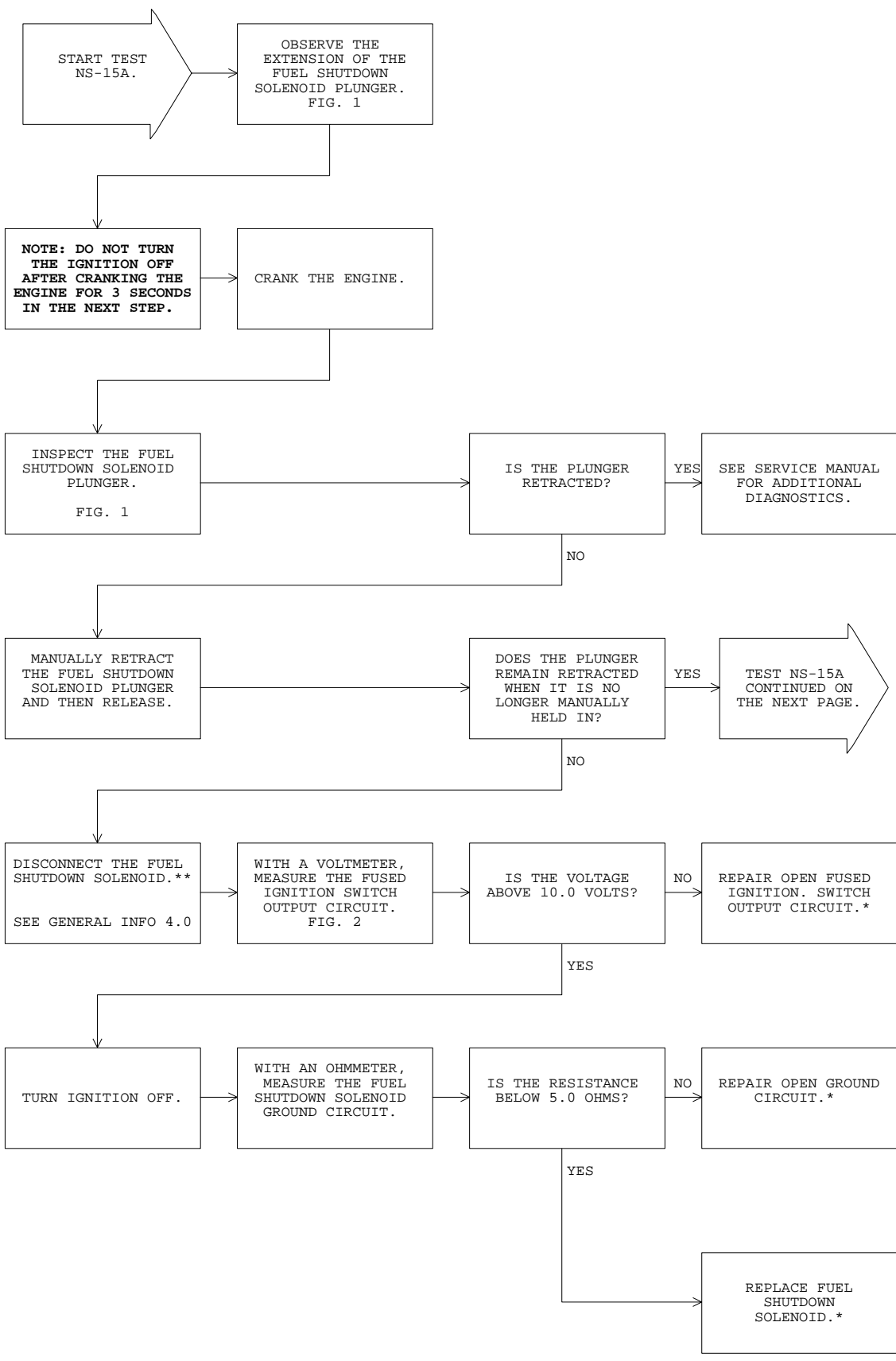

***Perform Verification TEST VER-1A.**

****Check connectors - Clean / repair as necessary.**

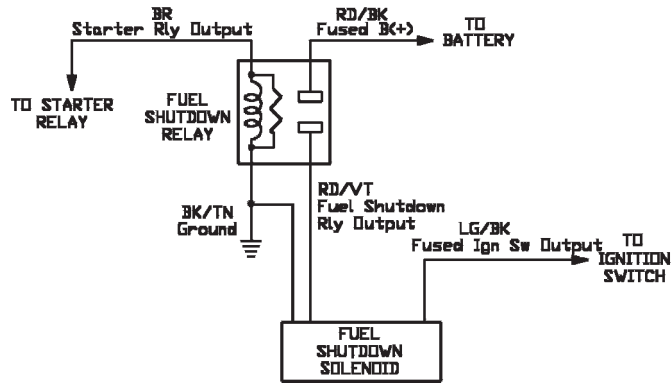

2310606

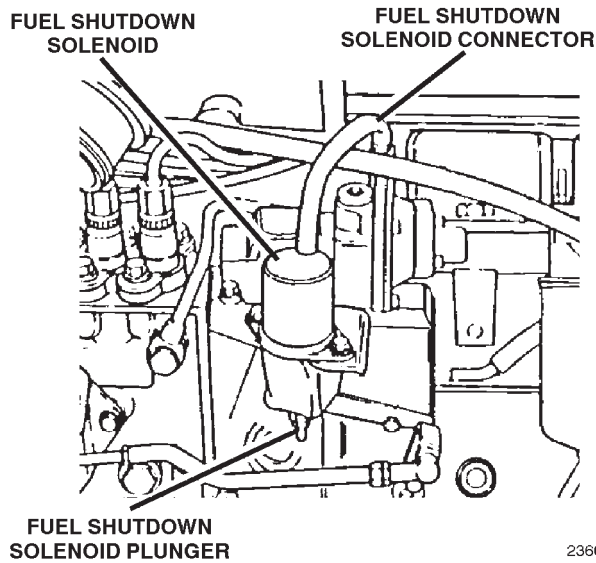
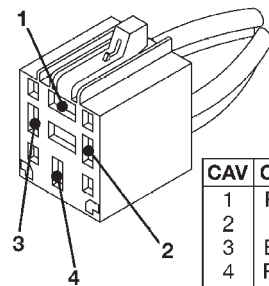

FIG. 1

2360502



FUEL SHUTDOWN RELAY CONNECTOR

CAV	COLOR	FUNCTION
1	RD/VT	Fuel Shutdown Relay Output
2	BR	Starter Relay Output
3	BK/TN	Ground
4	RD/BK	Fused B(+)

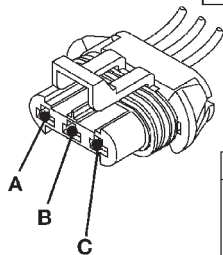

FUEL SHUTDOWN SOLENOID CONNECTOR

CAV	COLOR	FUNCTION
A	LG/BK	Fused Ignition Switch Output
B	RD/VT	Fuel Shutdown Relay Output
C	BK/TN	Ground

FIG. 2

80aa4be8

TEST NS-15A CONTINUED - CHECKING THE FUEL SHUTDOWN RELAY AND SOLENOID (DIESEL)

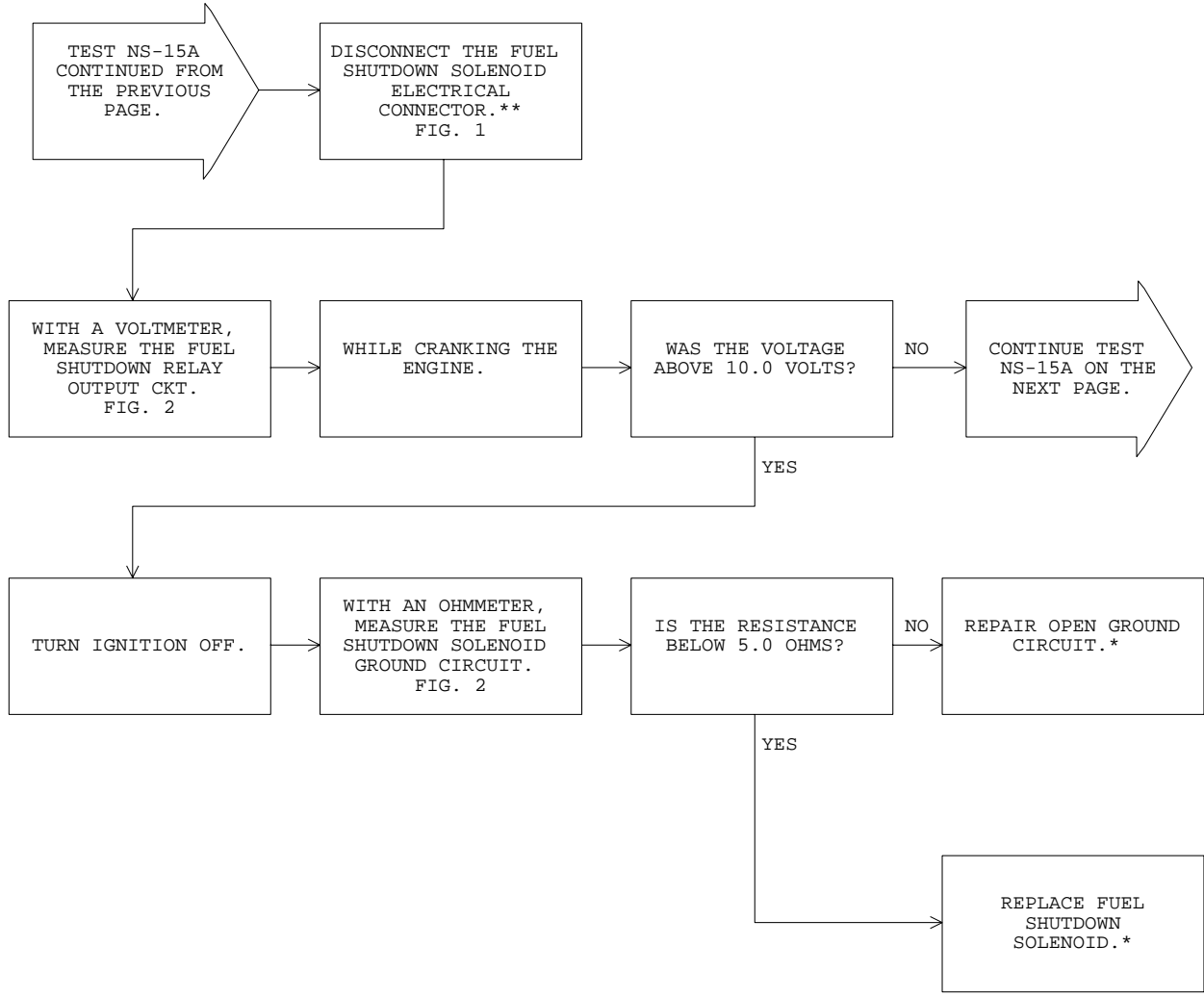

**Perform Verification TEST VER-1A.*

***Check connectors - Clean / repair as necessary.*

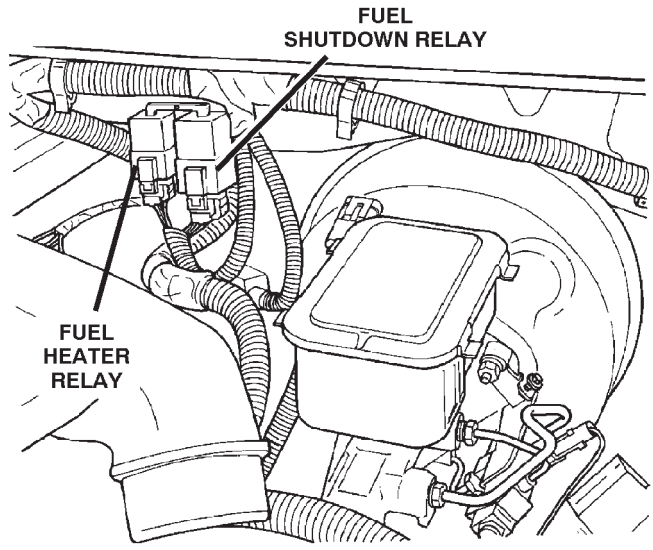
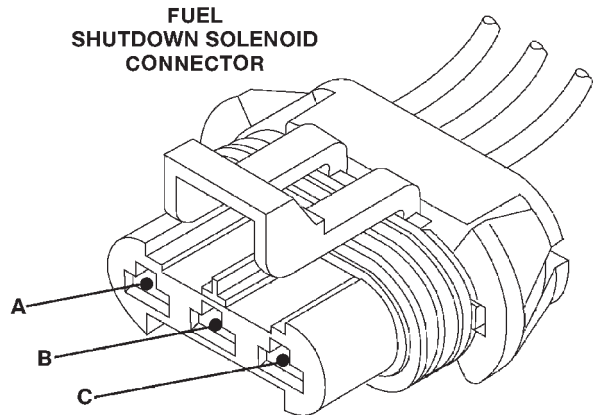

FIG. 1

2310503



CAV	COLOR	FUNCTION
A	LG/BK	Fused Ignition Switch Output
B	RD/VT	Fuel Shutdown Relay Output
C	BK/TN	Ground

FIG. 2

80aa4c3e

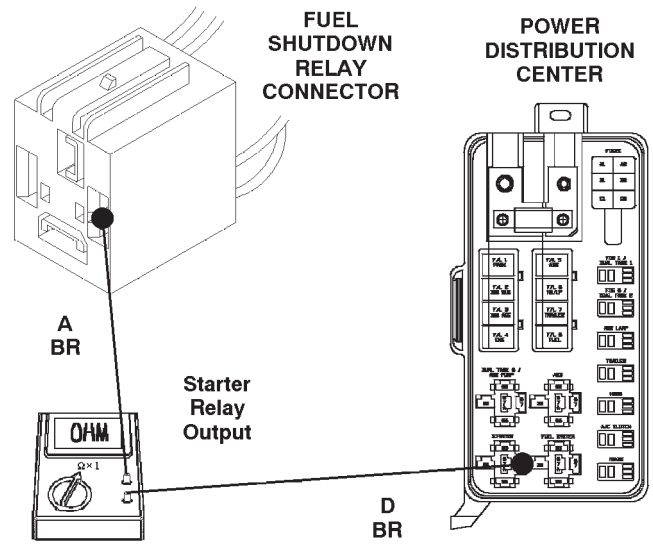
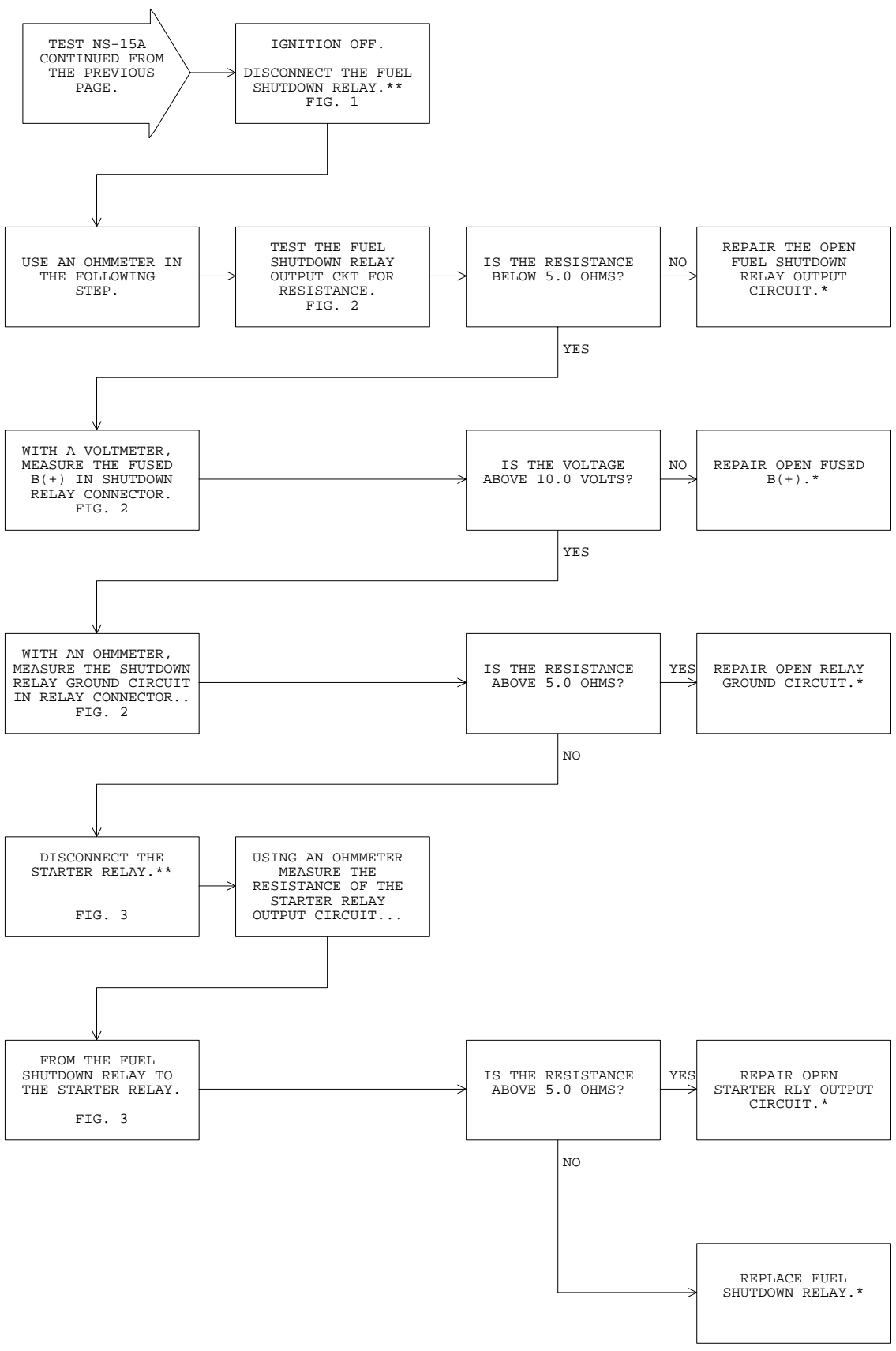

FIG. 3

4160305

TEST NS-15A CONTINUED - CHECKING THE FUEL SHUTDOWN RELAY AND SOLENOID (DIESEL)



**Perform Verification TEST VER-1A.*

***Check connectors - Clean / repair as necessary.*